

**Mex Endless Orange ~HRC65**  
**UH Red HRC50~70**





## MEX - UH

🇬🇧 Mex (micro grain solid carbide and “endless orange” coating) and Uh (nano micro grain carbide and “Uh red” coating): a top-level range of end mills for middle-hard and hard steel, up to 70 HRC.

🇮🇹 Mex (metallo duro micro grana e rivestimento “Endless orange”) ed Uh (nano micro grana e rivestimento “Uh red”): una gamma di altissimo livello per acciai medio duri e duri fino a 70HRC.

🇩🇪 Mex (Feinkorn- Hartmetall und „Endless orange“-Beschichtung) sowie Uh (Nano- Feinkorn und „Uh red“-Beschichtung) Fräser bieten höchste Leistungen für mittel und hoch gehärtete Stähle bis 70 HRC.

🇫🇷 Mex (carbure micro grain et revêtement «Endless orange») et UH (carbure nano micro grain et revêtement «Uh red») : une gamme de fraisage de très haut niveau pour aciers durs jusqu’à 70 HRC.

**MEX**

**UMG**

**ENDLESS ORANGE COATING**  
ULTRA FINE MICROGRAIN

~HRC65

**UH**

**NMG**

**UH RED COATING**  
NANO MICROGRAIN

HRC50-70

PAGE 233

MEXMB2 - MEXCLSB2 - MEX253

Ø mm	~6	>6
tol. D µ	0 / -12	0 / -15
tol. R µ	±10	±10

MEXCSB2

Ø mm	~6	>6
tol. D µ	0 / -30	0 / -30
tol. R µ	±10	±10

MEXMB2 MEXCSB2 MEXCLSB2 MEX253

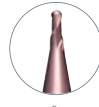

MEXMB2				
MEXCSB2 MEXCLSB2 MEX253				

D	d	l	L	Stock	Stock	Stock	Stock
mm 0.1	4	0.2	40	○ NEW			
0.2	4	0.4	40	○ NEW			
0.3	4	0.6	40	○ NEW			
0.4	4	0.8	40	○ NEW			
0.5	4	1	40	○ NEW			
0.6	4	1.2	40	●			
0.7	4	1.4	40	●			
0.8	4	1.6	40	●			
0.9	4	1.8	40	○			
1	3	3	38		●		
1	4	2.5	50			●	
1.2	4	3	50			● NEW	
1.5	3	3	38		●		
1.5	4	4	50			●	
2	6	3	50		●		
2	6	5	50			●	
2	6	4	80				●
2.5	6	6	60				
3	6	4	50		●		
3	6	8	60			●	
3	6	6	100				●
4	6	5	54		●		
4	6	8	70			●	
4	6	8	100				●
5	6	6	54		●		
5	6	10	80			●	
5	6	10	120				●
6	6	12	60		●		
6	6	12	90			●	
6	6	12	120				●
7	8	8	58	○			
7	8	14	90			○	
8	8	14	60		●		
8	8	14	100			●	
8	8	16	150				●
9	10	10	66	○			
9	10	18	100			○	

● stock standard ○ non-standard stock EX stock exhaustion

**n** **Vf**  
PAGE 233

**OSAWA  
NORM**

**MEXMB2 - MEXCLSB2 - MEX253**

Ø mm	~6	>6
tol. D µ	0 / -12	0 / -15
tol. R µ	±10	±10

**MEXCSB2**

Ø mm	~6	>6
tol. D µ	0 / -30	0 / -30
tol. R µ	±10	±10

**MEXMB2 MEXCSB2 MEXCLSB2 MEX253**

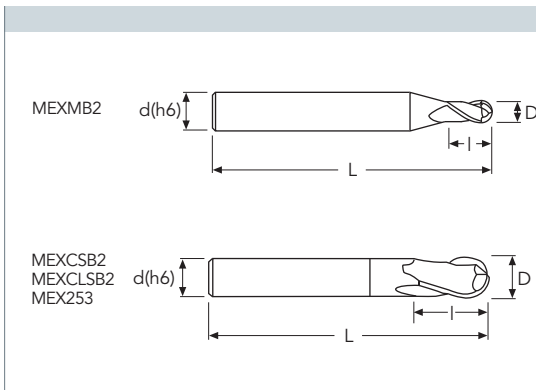
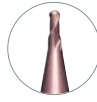

D	d	l	L	Stock	Stock	Stock	Stock
mm 10	10	18	70		●		
10	10	18	100			●	
10	10	20	180				●
12	12	22	80		●		
12	12	22	110			●	
12	12	24	200				●
14	12	26	100			●	
16	16	30	150			●	
18	18	34	150			○	
20	20	38	150			○	

● stock standard ○ non-standard stock EX stock exhaustion

**n** **Vf**  
PAGE 234

**OSAWA**  
**NORM**

**MEXCRB2**



**MEXCRB2**

Ø mm	~6
tol. D µ	0 / -12
tol. R µ	±10

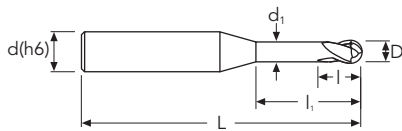

$d_1 < D$



D	d	l	l1	L	Stock
mm 0.4	4	0.4	3	45	●
0.5	4	0.5	6	45	●
0.5	4	0.5	8	45	●
0.6	4	0.6	6	45	●
0.6	4	0.6	8	45	●
0.8	4	0.8	6	45	●
0.8	4	0.8	8	45	●
1	4	1	6	45	●
1	4	1	8	45	●
1	4	1	12	45	●
1	4	1	16	50	●
1	4	1	20	55	●
1.2	4	1.2	8	45	●
1.2	4	1.2	12	45	●
1.4	4	1.4	12	45	●
1.5	4	1.5	8	45	●
1.5	4	1.5	12	45	●
1.5	4	1.5	16	50	●
1.5	4	1.5	20	55	●
1.6	4	1.6	20	55	●
1.8	4	1.8	16	50	●
1.8	4	1.8	20	55	○
2	4	2	8	45	●
2	4	2	12	50	●
2	4	2	16	50	●
2	4	2	20	55	●
2	4	2	26	70	●
2	4	2	30	70	●
3	6	3	16	55	●
3	6	3	20	60	●
3	6	3	26	70	●
3	6	3	30	70	●
4	6	4	16	60	●
4	6	4	20	65	●
4	6	4	26	70	●
4	6	4	30	70	●

● stock standard ○ non-standard stock EX stock exhaustion



  
 PAGE 234

**OSAWA**  
**NORM**

**MEXCRB2**

Ø mm	~6
tol. D µ	0 / -12
tol. R µ	±10

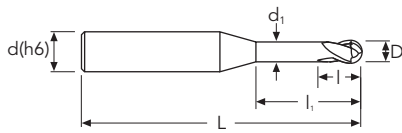
**MEXCRB2**



D	d	l	l1	L	Stock
mm 4	6	4	40	90	●
4	6	4	50	100	○
5	6	5	20	60	●
5	6	5	30	80	●
6	6	6	30	90	●
6	6	6	40	100	●
6	6	6	50	110	●

● stock standard   ○ non-standard stock   EX stock exhaustion

	<b>OSAWA NORM</b>
PAGE 234-235	

MEXM2 - MEXCS2

Ø mm	~25
tol. D µ	0 / -12

MEXCL2

Ø mm	~16
tol. D µ	0 / -30



<p>MEXM2</p>				
<p>MEXCS2 MEXCL2</p>				

D	d	l	L	Stock	Stock	Stock
mm 0.1	4	0.2	40	○ NEW		
0.2	4	0.4	40	○ NEW		
0.3	4	0.6	40	● NEW		
0.4	4	0.8	40	●		
0.5	4	1	40	●		
0.6	4	1.2	40	●		
0.7	4	1.4	40	●		
0.8	4	1.6	40	●		
0.9	4	1.8	40	○		
1	4	2.5	40		●	
1	6	8	60			○ NEW
1.1	4	2.5	40	○		
1.2	4	4	40	●		
1.3	4	4	40	○		
1.4	4	4	40	●		
1.5	4	4	40		●	
1.5	6	12	60			○ NEW
2	4	6	40		●	
2	6	12	60			●
2.5	4	8	40		●	
3	6	8	55		●	
3	6	15	60			●
3.5	6	10	55		●	
4	6	10	55		●	
4	6	20	60			●
4.5	6	12	55		●	
5	6	13	55		●	
5	6	25	70			●
5.5	6	14	55		●	
6	6	15	60		●	
6	6	25	70			●
6.5	8	17	65		●	
7	8	18	65		●	
7.5	8	19	65		○	
8	8	20	70		●	
8	8	30	80			●

● stock standard ○ non-standard stock EX stock exhaustion



	<b>OSAWA NORM</b>
PAGE 234-235	

MEXM2 - MEXCS2

Ø mm	~25
tol. D µ	0 / -12

MEXCL2

Ø mm	~16
tol. D µ	0 / -30



<p>MEXM2</p>			
<p>MEXCS2 MEXCL2</p>			

D	d	l	L	Stock	Stock	Stock
mm 8.5	10	21	70		●	
9	10	23	70		●	
9.5	10	24	70		○	
10	10	22	75		●	
10	10	35	90			●
11	12	28	75		●	
12	12	26	80		●	
12	12	40	90			●
13	12	35	90		○	
14	12	35	90		●	
14	16	50	110			○
15	16	38	90		○	
16	16	32	100		●	
16	16	50	110			○
18	18	45	100			
20	20	40	100			
25	25	50	120		○	

● stock standard ○ non-standard stock EX stock exhaustion

**n** **Vf**  
PAGE 236

**OSAWA**  
**NORM**

**MEXCR2**



**MEXCR2**

Ø mm	~6
tol. D µ	0 / -12

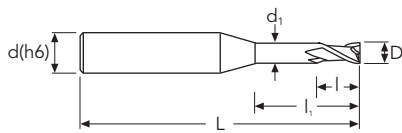

$d_1 < D$



D	d	l	l1	L	Stock
mm 0.4	4	0.6	4	45	●
0.5	4	0.7	6	45	●
0.5	4	0.7	8	45	●
0.6	4	0.9	6	45	●
0.6	4	0.9	8	45	●
0.7	4	1	6	45	●
0.7	4	1	8	45	○
0.8	4	1.2	6	45	●
0.8	4	1.2	10	45	○
0.8	4	1.2	12	45	●
0.9	4	1.35	10	45	○
0.9	4	1.35	15	50	○
1	4	1.5	6	45	●
1	4	1.5	8	45	●
1	4	1.5	12	45	●
1	4	1.5	16	50	●
1	4	1.5	20	55	●
1.2	4	1.8	12	45	●
1.2	4	1.8	16	50	●
1.4	4	2.1	12	45	●
1.4	4	2.1	16	50	●
1.4	4	2.1	22	55	●
1.5	4	2.3	8	45	●
1.5	4	2.3	10	45	●
1.5	4	2.3	12	45	●
1.5	4	2.3	16	50	●
1.5	4	2.3	20	55	●
1.6	4	2.4	20	55	●
1.8	4	2.7	12	45	○
1.8	4	2.7	20	55	●
2	4	3	12	45	●
2	4	3	16	50	●
2	4	3	20	55	●
2	4	3	26	60	●
2	4	3	30	70	●
2.5	4	3.7	12	45	●

● stock standard ○ non-standard stock EX stock exhaustion

**n** **Vf**  
PAGE 236

**OSAWA  
NORM**

**MEXCR2**



**MEXCR2**

Ø mm	~6
tol. D µ	0 / -12

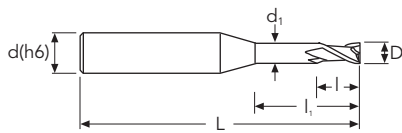

$d_1 < D$



D	d	l	l1	L	Stock
mm 2.5	4	3.7	20	60	●
2.5	4	3.7	30	80	●
3	6	4.5	14	50	●
3	6	4.5	18	55	●
3	6	4.5	26	65	●
3	6	4.5	30	70	●
3	6	4.5	40	90	●
4	6	6	16	60	○
4	6	6	20	60	●
4	6	6	26	70	●
4	6	6	30	70	○
4	6	6	40	90	●
4	6	6	50	100	○
5	6	7.5	20	60	○
5	6	7.5	26	70	●
5	6	7.5	30	80	●
5	6	7.5	50	110	●
6	6	9	30	90	●
6	6	9	50	110	●

● stock standard    ○ non-standard stock    EX stock exhaustion

n  
PAGE 237

Vf

**OSAWA  
NORM**

MEXCS4 - MEXCL4

$\varnothing$ mm	~25
tol. D $\mu$	0 / -30



D	d	l	L	Stock	Stock
mm 2	4	6	40	●	
2	4	8	40		●
2.5	4	8	40	●	
3	6	8	45	●	
3	6	12	50		●
3.5	6	10	45	●	
4	6	11	45	●	
4	6	15	50		●
4.5	6	11	45	●	
5	6	13	50	●	
5	6	20	60		●
5.5	6	13	50	●	
6	6	13	50	●	
6	6	20	60		●
6.5	8	17	65	●	
7	8	18	65	●	
7.5	8	19	65	○	
8	8	20	70	●	
8	8	30	80		●
8.5	10	21	70	○	
9	10	23	70	●	
9.5	10	24	70	○	
10	10	22	75	●	
10	10	35	90		●
11	12	28	75	●	
12	12	26	80	●	
12	12	40	90		●
13	12	35	90	○	
14	12	35	90	●	
14	16	50	110		●
15	16	26	90	○	
16	16	32	100	●	
16	16	50	110		●
18	18	32	100	○	
18	20	50	110		○
20	20	38	105	●	

● stock standard    ○ non-standard stock    EX stock exhaustion

**n** **Vf**  
PAGE 237

**OSAWA  
NORM**

MEXCS4 - MEXCL4

Ø mm	~25
tol. D µ	0 / -30

MEXCS4 MEXCL4

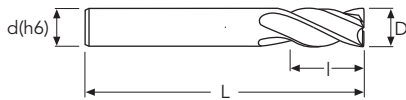

Z4	Z4
UMG ENDLESS ORANGE	UMG ENDLESS ORANGE
MEX	MEX
30°	30°

D	d	l	L	Stock	Stock
mm 20	20	55	110		●
25	25	50	120	●	
25	25	70	130		●

● stock standard ○ non-standard stock EX stock exhaustion

**n** **Vf**  
PAGE 238

**OSAWA  
NORM**

**MEXCSHM - MEXCLHM**

Ø mm	~25
tol. D µ	0 / -30

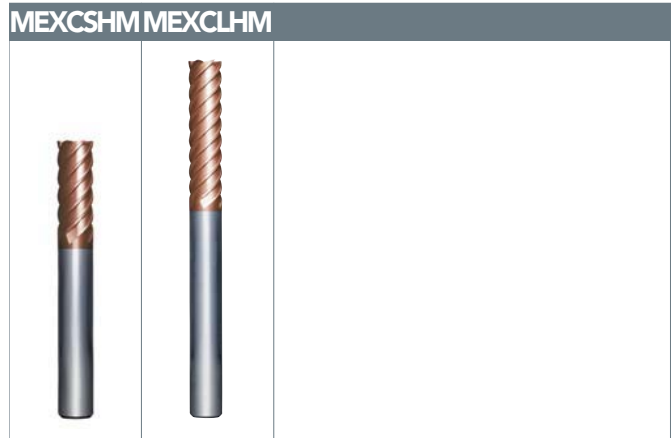

Z6-Z8

Z6

UMG  
ENDLESS ORANGE

UMG  
ENDLESS ORANGE

MEX

MEX

45°

45°

D	d	l	L	Stock	Stock
mm 6	6	15	60	●	
6	6	25	80		●
7	8	20	65	○	
8	8	20	70	●	
8	8	40	100		●
9	10	23	70	○	
10	10	25	80	●	
10	10	45	120		●
12	12	30	80	●	
12	12	60	120		●
14	14	35	100	●	
16	16	40	100	●	
16	16	80	150		●
18	18	45	100	○*	
20	20	50	100	●*	
20	20	80	150		●
25	25	50	100	○*	
25	25	90	150		●

\* Z=8

● stock standard   ○ non-standard stock   EX stock exhaustion

	<b>OSAWA NORM</b>
PAGE 239	

MEX610R - MEX611R

Ø mm	~20
tol. D µ	0 / -30
tol. R µ	±20

MEX610R MEX611R

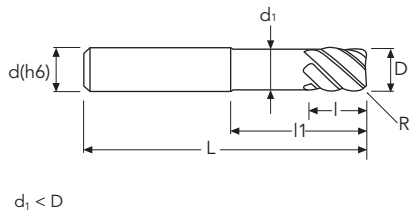

D	d	l	l1	L	Stock	Stock
mm 6 R0.5	6	6	14	50	●	
6 R0.5	6	15		90		●
8 R0.5	8	8	24	60	●	
8 R0.5	8	20		100		●
10 R0.5	10	25		100		●
10 R1.0	10	10	30	70	●	
10 R1.0	10	25		100		●
12 R0.5	12	30		100		●
12 R1.0	12	12	30	75	●	
12 R1.0	12	30		100		●
16 R1.0	16	40		150		○
20 R1.0	20	50		150		○

● stock standard   ○ non-standard stock   EX stock exhaustion

	<b>OSAWA NORM</b>
PAGE 240-241	

MEXCL2R - MEXCL4R - MEX410R

Ø mm	~6	>6
tol. D µ	0 / -12	0 / -15
tol. R µ	±20	±20



<p>MEXCL2R MEXCL4R</p>			
<p>MEX410R</p>			

D	d	l	l1	L	Stock	Stock	Stock
mm 2 R0.2	6	2.5	5	50			●
2.5 R0.25	6	3	6	50			●
3 R0.3							●
3 R0.3	6	8		50	●	●	
4 R0.3	6	10		50	●	●	
4 R0.5	6	5	9	50			●
4 R0.5	6	10		50	●		
5 R0.3	6	13		50	○	●	
5 R0.5	6	6	12	50			●
5 R0.5	6	13		50	●	●	
6 R0.3	6	15		60	●	●	
6 R0.5	6	7	14	60			●
6 R0.5	6	15		60	●	●	
6 R1.0	6	15		60	●	●	
8 R0.3	8	20		70	○	○	
8 R0.5	8	20		70	●	●	
8 R1.0	8	10	18	70			●
8 R1.0	8	20		70	●	●	
8 R2.0	8	25		70	○	●	
10 R0.3	10	25		90	○	●	
10 R0.5	10	25		90	●	●	
10 R1.0	10	12	25	75			●
10 R1.0	10	25		90	●	●	
10 R2.0	10	25		90	●	●	
12 R0.5	12	30		100	○	○	
12 R1.0	12	15	30	80			●
12 R1.0	12	30		100	○	●	
12 R2.0	12	30		100	●	●	
16 R1.0	16	40		110		○	
16 R2.0	16	40		110		●	
20 R1.0	20	45		110		○	
20 R2.0	20	45		110		○	

● stock standard ○ non-standard stock EX stock exhaustion



**n** **Vf**  
PAGE 241

**OSAWA  
NORM**

MEXWSFR - MEXCSFR

Ø mm	~6	7~10	11~18	20
tol. D µ	0 / -48	0 / -58	0 / -70	0 / -84

MEXWSFR MEXCSFR

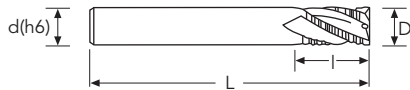

Z3-Z4	Z3-Z4
UMG <b>ENDLESS</b>	UMG <b>ENDLESS</b>
MEX HR FINE	MEX HR FINE
20°	20°

D	d	l	L	Z	Stock	Stock
mm 6	6	15	60	3		●*
7	6	18	70	3		○*
8	8	16	63	3	EX	●*
8	8	20	65	3		○
9	10	22	70	4		●
10	10	25	70	4		●
12	12	30	80	4		●
14	14	25	100	4		●
16	16	32	92	4	EX	●
16	16	40	100	4		●
20	20	38	104	4	EX	●
20	20	50	100	4		●

● stock standard ○ non-standard stock EX stock exhaustion

**UH Red HRC50~70**

	<b>OSAWA NORM</b>
PAGE 242	

UHCSB2 - UH250

Ø mm	~6	>6
tol. D µ	0 / -12	0 / -15
tol. R µ	±5	±10



<p>Technical drawing of UHCSB2 drill bit showing dimensions: d(h6), L, I, D.</p>		

D	d	I	I1	L	Stock	Stock
mm 0.1	6	0.1		40	○	
0.2	6	0.2		40	○	
0.3	6	0.3		40	○	
0.4	6	0.4		40	●	
0.5	6	0.5		40	●	
0.6	6	0.6		40	●	
0.7	6	0.7		40	○	
0.8	6	0.8		40	●	
0.9	6	0.9		40	○	
1	6	1.5		40	●	
1	4	1	2.2	50		●
1.5	6	2.5		40	●	
1.5	4	1.5	3	50		●
2	6	3		40	●	
2	6	2	4	50		●
2.5	6	3		50	●	
3	6	4.5		50	●	
3	6	3	6	60		●
4	6	6		50	●	
4	6	4	8	70		●
5	6	7.5		50	●	
5	6	5	10	80		●
6	6	9		50	●	
6	6	6	12	90		●
8	8	12		50	●	
8	8	8	16	100		●
10	10	15		60	●	
10	10	10	20	100		●
12	12	18		60	●	
12	12	12	24	110		●

● stock standard ○ non-standard stock EX stock exhaustion

**n** **Vf**  
PAGE 242

**OSAWA  
NORM**

**UHCRB2**

Ø mm	-6
tol. D µ	0 / -12
tol. R µ	±5

**UHCRB2**

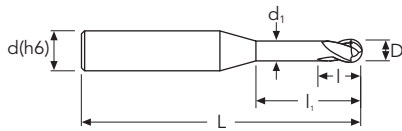

$d_1 < D$



D	d	l	l1	L	Stock
mm 0.1	4	0.1	0.3	45	●
0.2	4	0.2	0.6	45	○
0.2	4	0.2	1	45	●
0.3	4	0.3	2	45	●
0.3	4	0.3	3	45	○
0.4	4	0.4	1	45	●
0.4	4	0.4	3	45	●
0.5	6	0.5	2	45	●
0.5	4	0.5	2	45	○
0.5	6	0.5	4	45	●
0.5	4	0.5	6	45	○
0.6	6	0.6	2	45	○
0.6	6	0.6	4	45	●
0.6	4	0.6	6	45	●
0.6	4	0.6	10	45	○
0.8	6	0.8	2	45	●
0.8	6	0.8	6	45	●
0.8	4	0.8	10	45	○
1	6	1	3	50	●
1	6	1	6	50	●
1	4	1	10	50	●
1	6	1	10	50	●
1	4	1	16	50	●
1	4	1	20	55	●
1.2	6	1.2	4.4	50	○
1.2	6	1.2	8	50	●
1.2	4	1.2	12	50	○
1.5	6	1.5	4	50	●
1.5	6	1.5	10	50	●
1.5	4	1.5	12	50	●
1.5	6	1.5	12	50	●
1.5	4	1.5	20	55	●
2	6	3	6	50	●
2	4	3	10	50	●
2	6	3	15	50	●
2	4	3	16	50	●

● stock standard ○ non-standard stock EX stock exhaustion

**n** **Vf**  
PAGE 242

**OSAWA  
NORM**

**UHCRB2**

Ø mm	-6
tol. D µ	0 / -12
tol. R µ	±5

**UHCRB2**

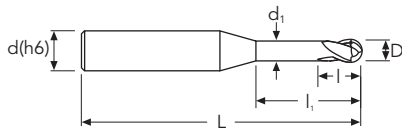

$d_1 < D$



D	d	l	l1	L	Stock
mm 2	6	3	20	50	●
2	4	3	25	60	●
2	4	3	30	70	●
3	6	4	12	55	●
3	6	4	16	55	●
3	6	4	20	60	●
3	6	4	30	70	●
4	6	5	16	55	●
4	6	5	20	60	●
4	6	5	30	70	●
4	6	5	40	80	●

● stock standard    ○ non-standard stock    EX stock exhaustion

**n** **Vf**  
PAGE 243

**OSAWA**  
**NORM**

**UHF430**

Ø mm	~12
tol. D µ	0 / -20
tol. R µ	±5

**NEW**

**UHF430**

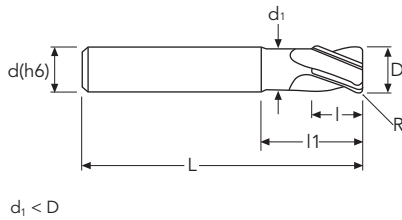

D	d	l	l1	L	Stock
mm 2 R0.5	6	1	6	70	●
3 R0.5	6	1.2	8	70	●
4 R0.5	6	1.5	10	70	●
5 R0.5	6	2	10	70	●
6 R0.5	6	2.5	12	90	●
6 R1	6	2.5	12	90	●
8 R1	8	3.5	16	100	●
8 R2	8	3.5	16	100	●
10 R1	10	4	20	100	●
10 R2	10	4	20	100	●
12 R2	12	5	25	110	●
12 R3	12	5	25	110	●

● stock standard   ○ non-standard stock   EX stock exhaustion

PAGE 244-245-246

**OSAWA**  
**NORM**

UHM2 - UHCS2

Ø mm	~6	>6
tol. D µ	0 / -12	0 / -15
tol. R µ	±10	±15



						UHM2	UHCS2
D	d	l	l1	L	Stock	Stock	
mm 0.3	6	0.45		50	●		
0.4	6	0.6		50	●		
0.5 R0.05	6	0.7		50	●		
0.6 R0.05	6	0.9		50	●		
0.8 R0.05	6	1.2		50	●		
1 R0.1	4	2	3	50		●	
1 R0.1	6	1.5		50	●		
1.5 R0.1	4	2.5	4	50		●	
1.5 R0.15	6	2.2		50	●		
2 R0.15	6	2.2		50	●		
3 R0.1	6	4.5	8	55		●	
4 R0.1	6	6	10	55		●	
5 R0.2	6	6	11	50		●	
6 R0.2	6	9	15	60		●	
8 R0.2	8	12	20	65		●	
10 R0.2	10	15	25	70		●	
12 R0.3	12	18	30	80		●	

● stock standard ○ non-standard stock EX stock exhaustion

PAGE 244

**OSAWA**  
**NORM**

UHCR2

Ø mm	~4
tol. D µ	0 / -12

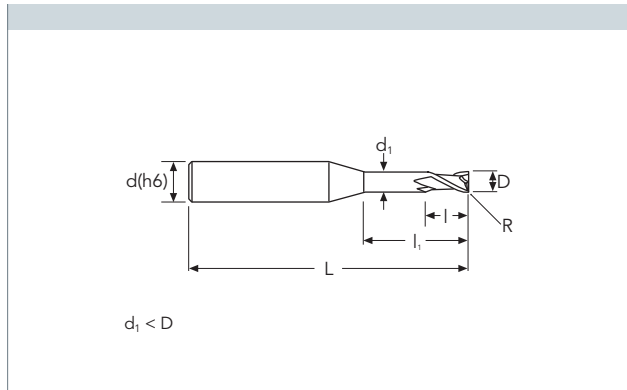
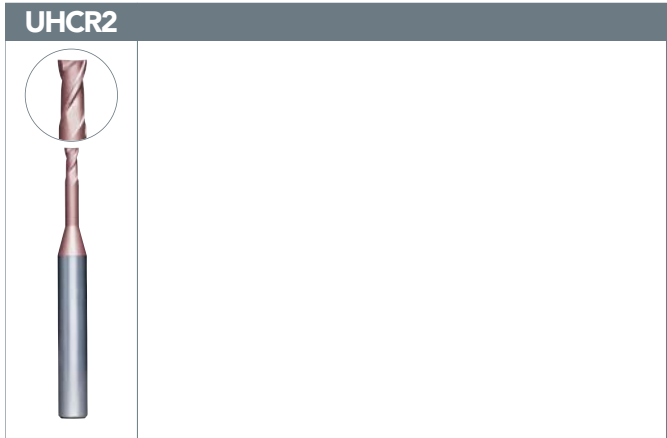

**UH RED**

D	d	l	l1	L	Stock
mm 0.1	4	0.15	0.3	45	○
0.2	4	0.3	1	45	●
0.3	4	0.45	1.5	45	●
0.3	4	0.45	3	45	●
0.4	4	0.6	3	45	○
0.4	4	0.6	5	45	●
0.5	4	0.7	2	45	● <b>NEW</b>
0.5	4	0.7	4	45	●
0.5	4	0.7	8	45	○
0.6 R0.05	6	0.9	2	50	EX
0.6 R0.05	6	0.9	4	50	EX
0.6	4	0.9	4	45	● <b>NEW</b>
0.6	4	0.9	6	45	●
0.8 R0.05	6	1.2	5.5	50	EX
0.8	4	1.2	8	45	●
1	4	1.5	4	50	● <b>NEW</b>
1 R0.10	6	1.5	6.7	50	EX
1	4	1.5	8	50	● <b>NEW</b>
1	4	1.5	10	50	●
1	4	1.5	16	50	●
1	4	1.5	20	55	●
1.2	4	1.8	4	50	● <b>NEW</b>
1.2	4	1.8	10	50	● <b>NEW</b>
1.5	4	2.3	6	50	● <b>NEW</b>
1.5	4	2.3	10	50	● <b>NEW</b>
1.5	4	2.3	16	50	●
1.5	4	2.3	20	55	●
2	4	3	6	50	● <b>NEW</b>
2	4	3	12	50	● <b>NEW</b>
2 R0.15	6	2.2	13	50	EX
2	4	3	16	50	●
2	4	3	20	55	●
3	6	4.5	12	55	●
3	6	4.5	16	55	●
3	6	4.5	20	60	●

● stock standard   ○ non-standard stock   EX stock exhaustion



**n** **Vf**  
PAGE 244

**OSAWA**  
**NORM**

**UHCR2**

Ø mm	~4
tol. D µ	0 / -12

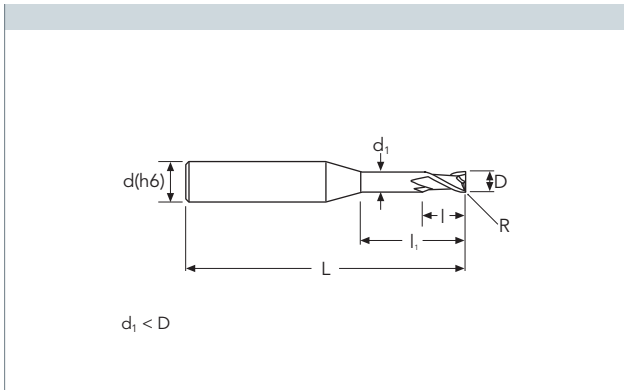
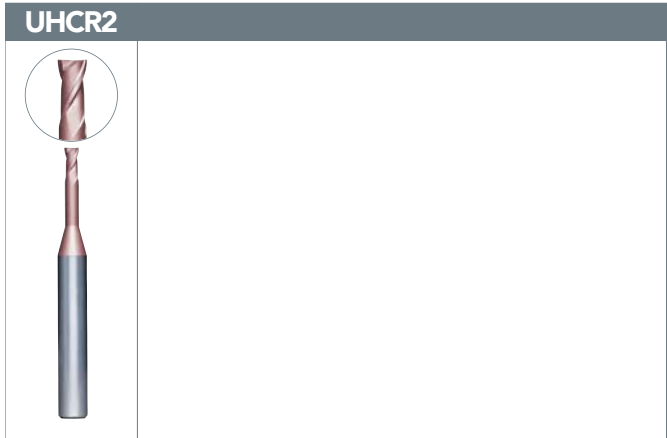

D	d	l	l1	L	Stock
mm 3	6	4.5	30	70	○
4	6	6	20	60	●
4	6	6	30	70	○
4	6	6	40	80	○

● stock standard   ○ non-standard stock   EX stock exhaustion

	<b>OSAWA NORM</b>
PAGE 246-247	

UH211

Ø mm	~6	>6
tol. D µ	0 / -12	0 / -15
tol. R µ	±10	±15

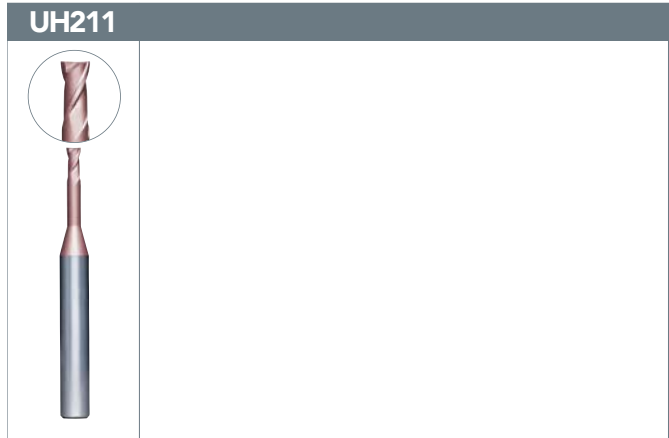

< D6

≥ D6

d<sub>1</sub> < D

Z2

NMG

UH RED

UH RADIUS

30°

D	d	l	l1	L	Stock	
0.5	R0.05	4	0.7	1.5	45	● NEW
0.5	R0.05	4	0.7	4	45	● NEW
0.6	R0.05	4	0.9	2	45	● NEW
0.6	R0.05	4	0.9	4	45	● NEW
0.8	R0.05	4	1.2	2	45	● NEW
0.8	R0.05	4	1.2	6	45	● NEW
1	R0.1	4	2	4	50	● NEW
1	R0.1	4	2	6	50	●
1	R0.1	4	2	8	50	● NEW
1	R0.2	4	2	4	50	●
1	R0.2	4	2	8	50	●
1	R0.3	4	2	4	50	●
1	R0.3	4	2	8	50	●
1.5	R0.1	4	2.5	6	50	● NEW
1.5	R0.1	4	2.5	10	50	● NEW
1.5	R0.2	4	2.5	4	50	●
1.5	R0.2	4	2.5	8	50	●
1.5	R0.2	4	2.5	12	50	●
1.5	R0.3	4	2.5	4	50	●
1.5	R0.3	4	2.5	8	50	●
2	R0.1	4	3	6	50	● NEW
2	R0.1	4	3	12	50	● NEW
2	R0.2	4	3	6	50	●
2	R0.2	4	3	12	50	●
2	R0.3	4	3	8	50	●
2	R0.3	4	3	12	50	●
2	R0.3	4	3	16	50	●
2	R0.5	4	3	6	50	●
2	R0.5	4	3	12	50	●
2.5	R0.2	4	3.5	8	55	● NEW
2.5	R0.2	4	3.5	12	55	● NEW
3	R0.2	6	4.5	10	55	●
3	R0.2	6	4.5	16	55	●
3	R0.3	6	4.5	10	55	●
3	R0.3	6	4.5	16	55	●
3	R0.5	6	4.5	10	55	●

● stock standard ○ non-standard stock EX stock exhaustion



  
 PAGE 246-247



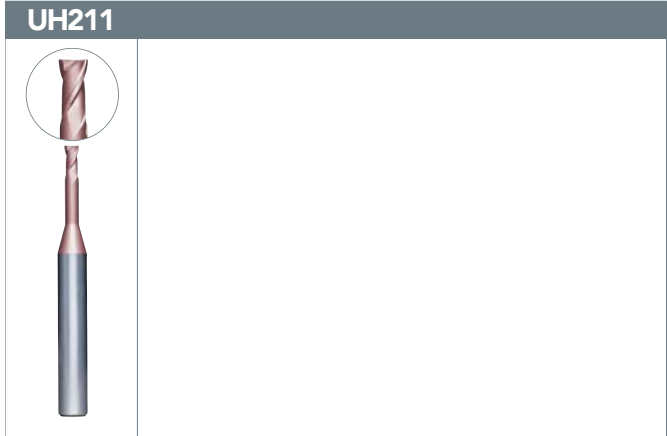

**OSAWA**  
**NORM**

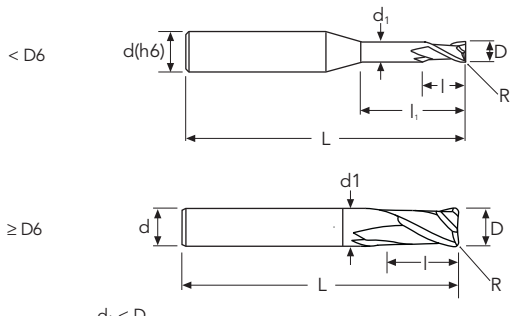
UH211

Ø mm	~6	>6
tol. D µ	0 / -12	0 / -15
tol. R µ	±10	±15







  

  

  

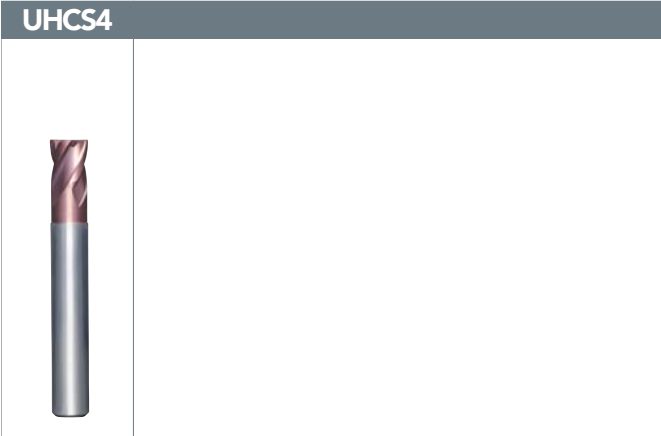

D	d	l	l1	L	Stock
mm 3 R0.5	6	4.5	16	55	●
4 R0.2	6	6	12	55	○
4 R0.2	6	6	20	60	●
4 R0.3	6	6	20	60	●
4 R0.5	6	6	12	55	●
4 R0.5	6	6	20	60	●
4 R1.0	6	6	16	55	●
6 R0.5	6	9	15	60	●
6 R1	6	9	15	60	●
6 R2	6	9	15	60	●
8 R0.5	8	12	20	65	●
8 R1	8	12	20	65	●
8 R2	8	9	25	60	●
10 R0.5	10	15	25	70	●
10 R1	10	15	25	70	●
10 R2	10	15	25	70	●
12 R0.5	12	18	30	80	○
12 R1	12	18	30	80	●
12 R2	12	18	30	80	●

● stock standard   ○ non-standard stock   EX stock exhaustion

**n** **Vf**  
PAGE 247

**OSAWA**  
**NORM**



UHCS4	~6	>6
Ø mm		
tol. D µ	0 / -12	0 / -15
tol. R µ	±10	±15

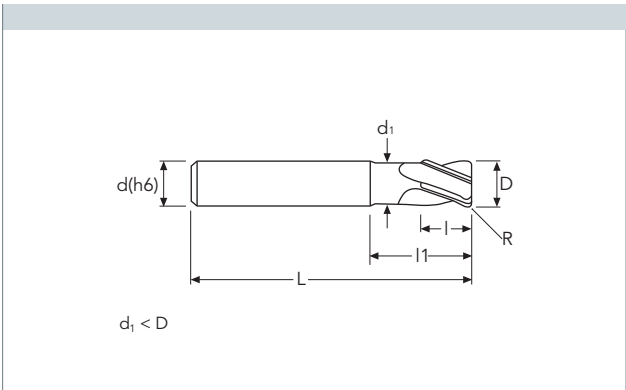

**Z4**

**NMG**  
**UH RED**

**UH RADIUS**

**30°**

D	d	l	l1	L	Stock	
<b>mm 1</b>	<b>R0.1</b>	4	2	3	50	●
<b>1.5</b>	<b>R0.1</b>	4	2.5	4	50	●
<b>2</b>	<b>R0.1</b>	4	3	6	50	●
<b>3</b>	<b>R0.1</b>	6	4	8	55	●
<b>4</b>	<b>R0.1</b>	6	6	10	55	●
<b>5</b>	<b>R0.2</b>	6	6	11	50	●
<b>6</b>	<b>R0.2</b>	6	9	15	60	●
<b>8</b>	<b>R0.2</b>	8	12	20	70	●
<b>10</b>	<b>R0.2</b>	10	15	25	70	●
<b>12</b>	<b>R0.3</b>	12	18	30	80	●

● stock standard   ○ non-standard stock   EX stock exhaustion

	<b>OSAWA NORM</b>
PAGE 248	

UH411 - UH412

Ø mm	~6	>6
tol. D µ	0 / -12	0 / -15
tol. R µ	±10	±15

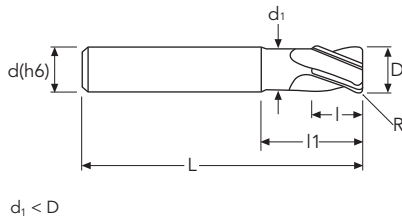

<b>NMG</b> <b>UH RED</b>	<b>NMG</b> <b>UH RED</b>

D	d	l	l1	L	Stock	Stock
mm 3 R0.3	6	4	12	55	●	
3 R0.3	6	4	20	60	●	
3 R0.5	6	4	10	55	●	
3 R0.5	6	4	20	60	●	
4 R0.3	6	6	12	55	●	
4 R0.3	6	6	20	60	●	
4 R0.5	6	6	12	55	●	
4 R0.5	6	6	20	60	●	
4 R1.0	6	6	12	55	●	
6 R0.5	6	9	15	60	●	
6 R0.5	6	9	20	90		●
6 R1.0	6	9	15	60	●	
6 R1.0	6	9	20	90		●
8 R0.5	8	12	20	70	●	
8 R0.5	8	12	25	100		●
8 R1.0	8	12	20	70	●	
8 R1.0	8	12	25	100		●
8 R2.0	8	12	20	70	●	
10 R0.5	10	15	25	70	●	
10 R0.5	10	15	32	100		●
10 R1.0	10	15	25	70	●	
10 R1.0	10	15	32	100		●
10 R2.0	10	15	25	70	●	
10 R2.0	10	15	32	100		●
12 R0.5	12	18	30	80	●	
12 R0.5	12	18	38	110		●
12 R1.0	12	18	30	80	●	
12 R1.0	12	18	38	110		●
12 R2.0	12	18	30	80	●	
12 R2.0	12	18	38	110		●

● stock standard ○ non-standard stock EX stock exhaustion

	<b>OSAWA NORM</b>
PAGE 248	

UH610R - UH611R

Ø mm	~20
tol. D µ	0 / -30
tol. R µ	±15

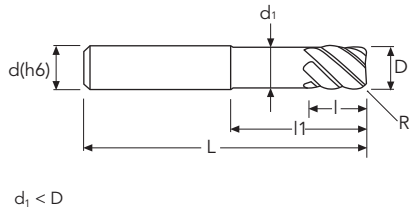
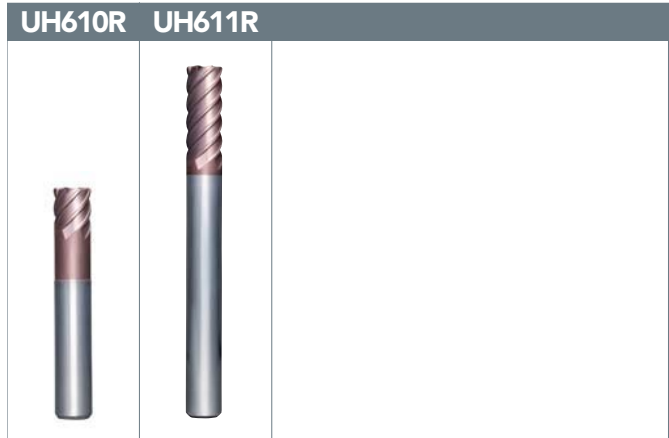

<b>NMG</b>	<b>NMG</b>
<b>UH RED</b>	<b>UH RED</b>
<b>45°</b>	<b>45°</b>

D	d	l	l1	L	Stock	Stock
<b>mm 6 R0.5</b>	6	6	15	50	●	
<b>6 R0.5</b>	6	15		70		●
<b>8 R0.5</b>	8	8	25	60	●	
<b>8 R0.5</b>	8	20		100		●
<b>10 R0.5</b>	10	25	30	100		●
<b>10 R1.0</b>	10	10	30	70	●	
<b>10 R1.0</b>	10	25		100		●
<b>12 R1.0</b>	12	12	30	75	●	
<b>12 R0.5</b>	12	30		110		●
<b>12 R1.0</b>	12	30		110		●
<b>16 R1.0</b>	16	32		130		●
<b>16 R1.5</b>	16	32		130		EX
<b>20 R1.0</b>	20	38		140		○
<b>20 R1.5</b>	20	38		140		EX
<b>20 R2.0</b>	20	38		140		○

● stock standard   ○ non-standard stock   EX stock exhaustion